



# FINE 3X TECHNICAL SPECIFICATIONS

FS#	FHB-T3-E1
Cre. Date	30 NOV, 2011
Rev. Date	
Page	1 of 4

## 1. EXTERNAL DIMENSIONS

Unit: mm

- X (Box) : Silenced Version - Adapter Mount

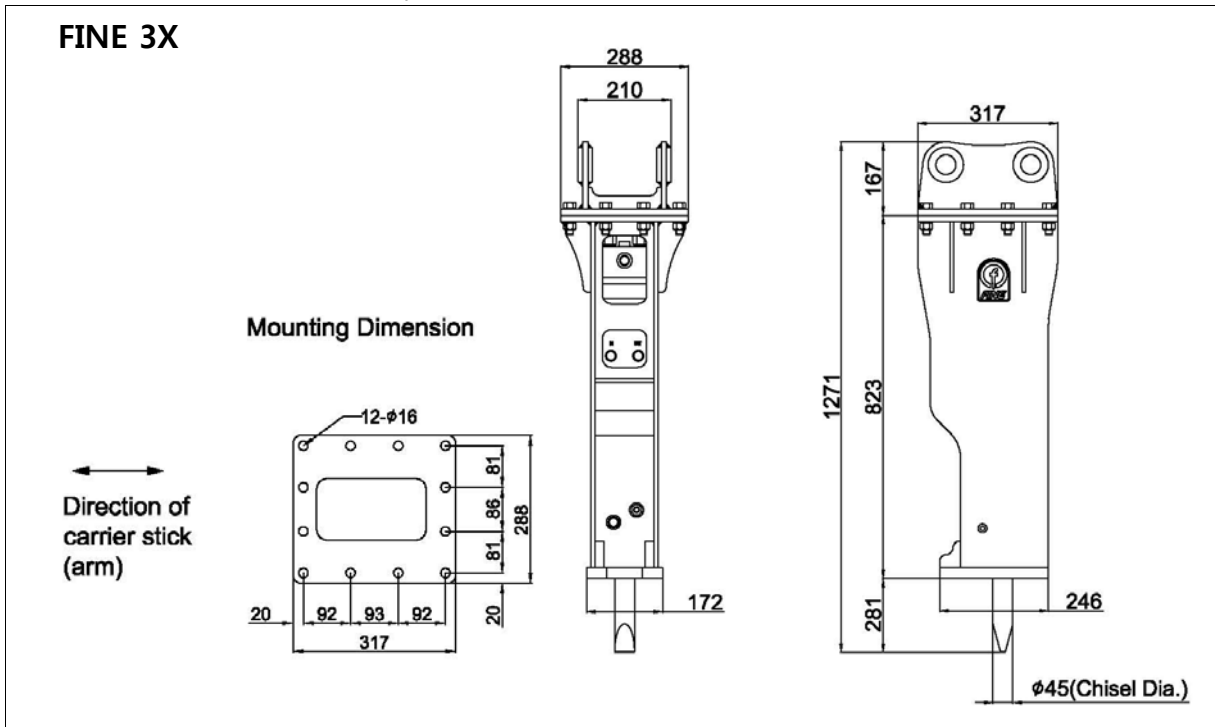

- Standard Mounting Adapter for X version

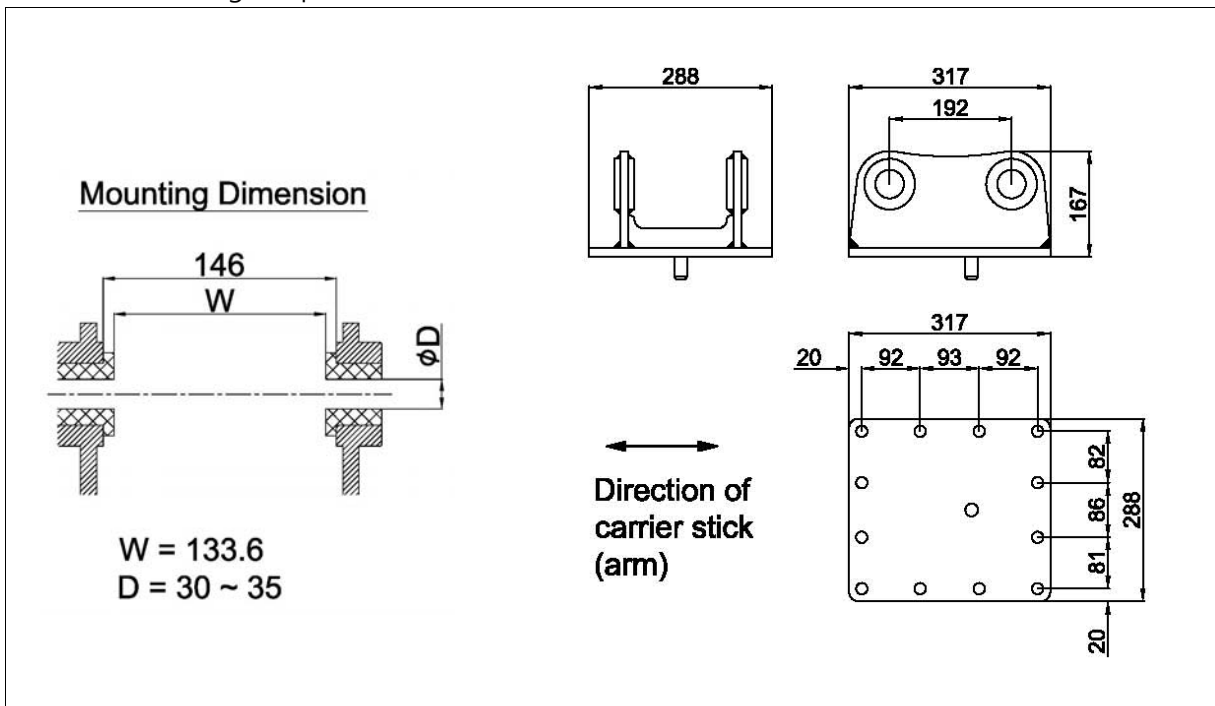



**FINE 3X**  
**TECHNICAL SPECIFICATIONS**

FS#	FHB-T3-E1
Cre. Date	30 NOV, 2011
Rev. Date	
Page	2 of 4

**2. BASIC SPECIFICATIONS**

Bracket Version	X (Box)		
Available Option			
2-speed control	Std.		
Dust protector	Opt.		
Auto-greasing kit	Opt.		
Working Weight <sup>1)</sup>	144 (318)		kg (lbs)
Weight without chisel and mounting adapter	118 (260)		kg (lbs)
Overall Length <sup>2)</sup>	2,338 (92)		mm (in.)
Weight of components			
Power-cell	65	(143)	kg (lbs)
Chisel(standard)	6	(13)	kg (lbs)
Mounting adapter <sup>3)</sup>	21	(46)	kg (lbs)
Required Oil Flow	20 ~ 30	(5.3 ~ 7.9)	lpm (gpm)
Operating Pressure	80 ~ 110	(1,160 ~ 1,595)	bar (psi)
Blow Frequency	600 ~ 1000		bpm
Impact Energy	248	(185)	J (ft.lbf)
Tool (chisel) Shank Diameter	45	(2.8)	mm (in.)
Applicable Carrier Weight			
Optimal range	1.3 ~ 1.8	(2.8 ~ 4)	t (klbs)
Available range	1.3 ~ 1.8	(2.8 ~ 4)	t (klbs)

Notes :

- 1) Total weight including standard tool, standard mounting adapter and spacers but excluding hydraulic hoses, fittings and mounting pins.
- 2) The length measured from the tool tip of the standard tool to the top of the breaker including mounting adapter.
- 3) Including standard mounting adapter, fasteners and spacers (for X version)



**FINE 3X**  
**TECHNICAL SPECIFICATIONS**

FS#	FHB-T3-E1
Cre. Date	30 NOV 2011
Rev. Date	
Page	3 of 4

**3. INSTALLATION SPECIFICATIONS**

Gas Charging Pressure <sup>1)</sup>				
Back-head (Piston accumulator) <sup>2)</sup>	16 ~ 17	(232 ~ 247)	bar	(psi)
Hydraulic Piping				
Line size (min. internal diameter)	13	(1/2)	mm	(in.)
Acceptable back pressure (max.) <sup>3)</sup>	10	(150)	bar	(psi)
Hose connections of breaker				
Oil supply (IN) & return (OUT)	BSP 1/2" O-Ring Boss Female			
Pressure Relief (min.)	40 (600) + measured max. operating pressure			
Acceptable Hydraulic Oil				
Operating temperature <sup>4)</sup>	-20 ~ +85	(-4 ~ +185)	°C	(°F)
Viscosity	1000 ~ 10		cSt	

Notes :











- 1) The prefill nitrogen gas pressure measured statically (breaker not operating) without down load on the tool at the stabilized gas temperature of +20 °C
- 2) The recommended value at the normal operating condition (supplied oil flow, oil temperature and viscosity, etc.)
- 3) The maximum allowed oil pressure at the breaker's connection point to the return line (measured statically without the breaker)
- 4) The allowed temperature limits when using the oil of viscosity grade 46



## FINE 3X TECHNICAL SPECIFICATIONS

FS#	FHB-T3-E1
Cre. Date	30 NOV, 2011
Rev. Date	
Page	4 of 4

### 4. AVAILABLE TOOLS (CHISELS)

Shank Diameter	45 (1.8) mm (in.)				
	<b>TYPE OF TOOL :</b>				
	Wedge Point	Moil Point	In Line Point	Blunt Point	Conical Point
Tool Diameter <sup>1)</sup>	45 (1.8)	45 (1.8)	45 (1.8)	45 (1.8)	45 (1.8) mm (in.)
Tool Length	500 (20)	500 (20)	500 (20)	500 (20)	500 (20) mm (in.)
Tool Weight	5.8(12.8)	5.6 (12.3)	5.8 (12.8)	6 (13.2)	5.6(12.3) kg (lbs)
Tool Shape					
					

Notes :

1) The diameter of the tool portion outside the breaker body

- Other special designs are also available on request.