



FINE 23X Plus TECHNICAL SPECIFICATIONS

FS#	FHB-T23-E1
Cre. Date	28 APR, 2011
Rev. Date	
Page	1 of 4

1. EXTERNAL DIMENSIONS

Unit: mm

- X (Box) : Silenced Version - Adapter Mount

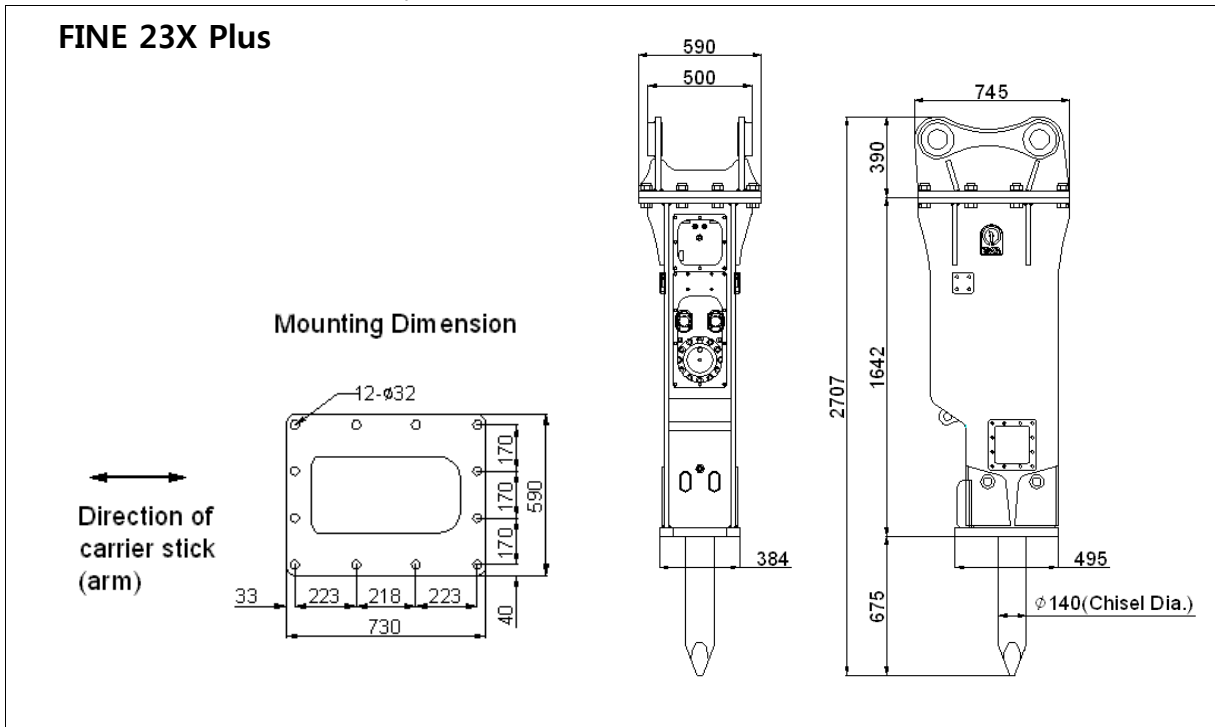

- Standard Mounting Adapter for plus version

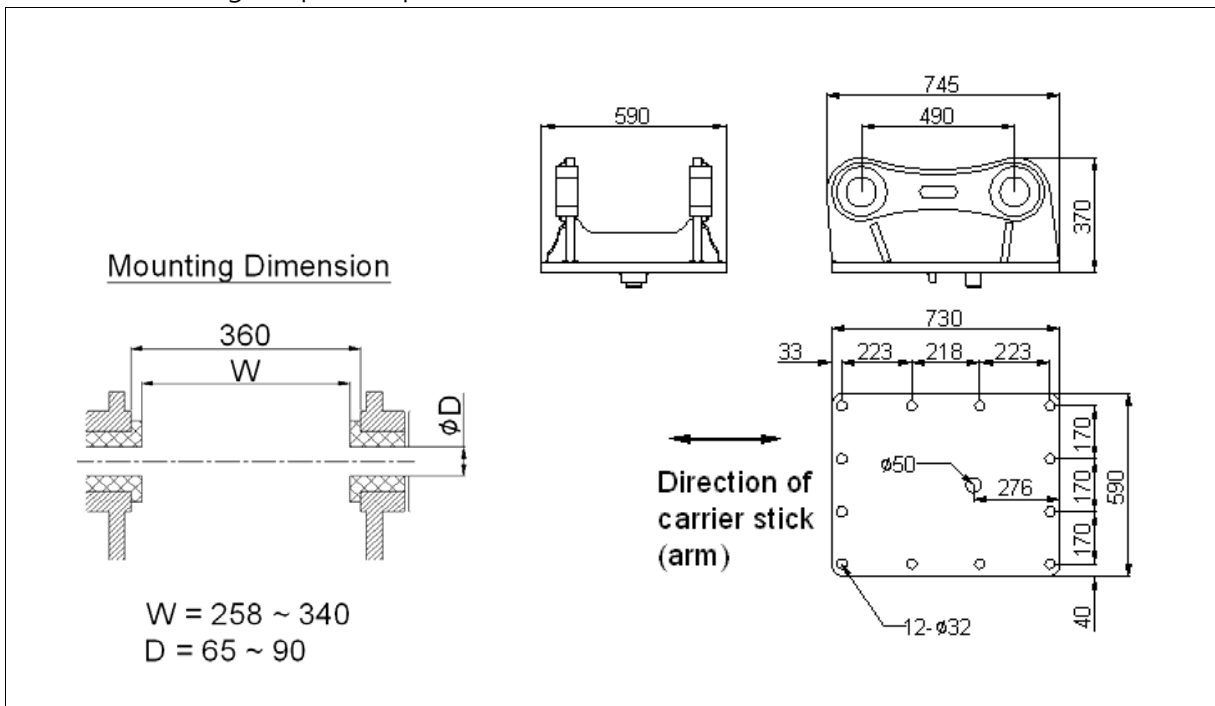



FINE 23X Plus
TECHNICAL SPECIFICATIONS

FS#	FHB-T23-E1
Cre. Date	28 APR, 2011
Rev. Date	
Page	2 of 4

2. BASIC SPECIFICATIONS

Bracket Version	X (Box)		
Available Option			
2-speed control	Std.		
Dust protector	Opt.		
Auto-greasing kit	Opt.		
Working Weight ¹⁾	1880 (4,144)		kg (lbs)
Weight without chisel and mounting adapter			kg (lbs)
Overall Length ²⁾	2,707 (107)		mm (in.)
Weight of components			
Power-cell	917	(2,021)	kg (lbs)
Chisel(standard)	116	(256)	kg (lbs)
Mounting adapter ³⁾			kg (lbs)
Required Oil Flow	120 ~ 180	(32 ~ 48)	lpm (gpm)
Operating Pressure	160 ~ 180	(2,321 ~ 2,611)	bar (psi)
Blow Frequency	350 ~ 550		bpm
Impact Energy	6,200	(4,573)	J (ft.lbf)
Tool (chisel) Shank Diameter	140	(5.51)	mm (in.)
Applicable Carrier Weight			
Optimal range	22 ~ 26	(49 ~ 57)	t (klbs)
Available range	22 ~ 26	(49 ~ 57)	t (klbs)

Notes :

- 1) Total weight including standard tool, standard mounting adapter and spacers but excluding hydraulic hoses, fittings and mounting pins.
- 2) The length measured from the tool tip of the standard tool to the top of the breaker including mounting adapter.
- 3) Including standard mounting adapter, fasteners and spacers (for plus version)



FINE 23X Plus
TECHNICAL SPECIFICATIONS

FS#	FHB-T23-E1
Cre. Date	28 APR, 2011
Rev. Date	
Page	3 of 4

3. INSTALLATION SPECIFICATIONS

Gas Charging Pressure ¹⁾				
Back-head (Piston accumulator) ²⁾	12 ~ 13	(170 ~ 189)	bar	(psi)
High pressure accumulator	60	(870)	bar	(psi)
Pressure Adjust Valve Setting ³⁾ (number of turns open from the full-close)	2.5 ~ 3.0		turns	
Hydraulic Piping				
Line size (min. internal diameter)	25	(1)	mm	(in.)
Acceptable back pressure (max.) ⁴⁾	10	(150)	bar	(psi)
Hose connections of breaker				
Oil supply (IN) & return (OUT)	BSP 1" O-Ring Boss Female			
Pressure Relief (min.)	40 (600) + measured max. operating pressure			
Acceptable Hydraulic Oil				
Operating temperature ⁵⁾	-20 ~ +85	(-4 ~ +185)	°C	(°F)
Viscosity	1000 ~ 10		cSt	

Notes :











- 1) The prefill nitrogen gas pressure measured statically (breaker not operating) without down load on the tool at the stabilized gas temperature of +20 °C
- 2) The recommended value at the normal operating condition (supplied oil flow, oil temperature and viscosity, etc.)
- 3) The value which is set at the factory to obtain the nominal operating pressure at the middle value of oil flow and back-head gas pressure.
- 4) The maximum allowed oil pressure at the breaker's connection point to the return line (measured statically without the breaker)
- 5) The allowed temperature limits when using the oil of viscosity grade 46



FINE 23X Plus TECHNICAL SPECIFICATIONS

FS#	FHB-T23-E1
Cre. Date	28 APR, 2011
Rev. Date	
Page	4 of 4

4. AVAILABLE TOOLS (CHISELS)

Shank Diameter	140 (5.51) mm (in.)				
	TYPE OF TOOL :				
	Wedge Point	Moil Point	In Line Point	Blunt Point	Conical Point
Tool Diameter ¹⁾	140 (5.51)	140 (5.51)	140 (5.51)	140 (5.51)	140 (5.51) mm (in.)
Tool Length	1200 (47)	1200 (47)	1200 (47)	1200 (47)	1200 (47) mm (in.)
Tool Weight	120.6 (265.9)	116.2 (256.2)	120.6 (265.9)	127.6 (281.3)	114.4 (252.2) kg (lbs)
Tool Shape					
					

Notes :

1) The diameter of the tool portion outside the breaker body

- Other special designs are also available on request.